

ELECTRO-MECHANICAL UNIT	Rated delivered power:	7,2 kW	Motor poles/revolutions:	2900 1/min - 2Poles
	Rated absorbed power:	8,76 kW	Motor phases:	T - Three-phase
	Rated absorbed current:	14,5 A	Service:	S1 submersible or w/sleeve
	Starting current:	60 A	Motor protection:	IP 68
	Starting torque:	39,2 Nm	Insulation class (ICL):	H
	Rated Cos Ø:	0,87	Max. Starts per hour:	15
	Rated motor performance:	82%	Standard cable type:	10 mt-H07RN-F 7G1,5+3x0,75
	Detailed description of series:	Submersible pump consisting of an electromechanical unit made of EN-GJL-250 cast iron, suitable for submersible operation, with 3 mechanical seals conventionally installed in an inspectable oil sump. Oil-bathed motor. Separate hydraulic unit. Explosion-proof version not available.*		
	Standard mechanical seals	1 mechanical silicon carbide (Viton) seal and 2 mechanical graphite alumina (NBR) seals		
	Lifting:	With handle on motor cover with possible hook-up for chain		
	Ball bearings:	Upper permanently lubricated ball bearing, lower oil-immersed ball bearing		
	Winding type:	Induction motor with oil-filled winding and manual overload protection		
Impregnation type:	Doubly impregnated humidity-resistant winding			
Direction of rotation:	Clockwise seen from top of electric pump			
Data provided above refers to hydraulic tests carried out at: 400/700 Volt 50 Hz				

MATERIALS	Mechanical unit:	EN-GJL-250 cast iron	Hyd. Unit, impeller:	EN-GJL-250 cast iron
	Shaft:	X30Cr13 (AISI420) steel	Bolts and Screws:	INOX A2 steel
	Seals (O-Ring):	NBR-SBR rubber	Grinder cutter:	Not applicable
	**Cooling jacket:	Not applicable	Painting:	Ecological epoxy vinyl
** Cooling jacket supplied upon request in series specified				

LIMITS ON USE REFERENCE STANDARDS	Max. operating temp.:	40 °C	Max. sub. depth:	20 m
	Liquid PH:	6 to 10	Liquid density:	1 kg/dm ³
	Viscosity of liquid:	1 mm ² /s	Max. acoustic press.:	< 70 dB dB
	Reference standards:			
	<ul style="list-style-type: none"> • EN 292-1; EN 292-2; CEI EN 60529; ISO 9906; CEI EN 60034-1. • CEI EN 60204; UNI ISO 6009; UNI EN 1561-1563; UNI EN 10098. • Low voltage directive 73/23/CEE. • Procedures specified by Zenit S.p.a. Quality System, UNI EN ISO 9001 (ISO 9001) certified, DNV n. SQ 0660-IT certified. • Machines directive 89/392/CEE and successive amendments thereto (directives 91/368/CEE, 93/68/CEE), electromagnetic compatibility directive 89/336/CEE 			

SYMBOLS		Product complying with European standards in force Company Quality System complying with UNI ISO norm
----------------	---	--

VARIANTS AVAILABLE	Electrical accessories	
	T	Thermistor
	TS	Thermistor and probe
	Set of mechanical seals	
	SIC2AL	1 mechanical silicon carbide (Viton) seal and 2 mechanical graphite alumina (NBR) seals
	2SICAL	2 mechanical silicon carbide (Viton) seals and 1 mechanical graphite alumina (NBR) seal
	Cooling system / mechanical seal flushing versions*	
	N	No sleeve and/or seal flushing
	CG	Generic cooling jacket

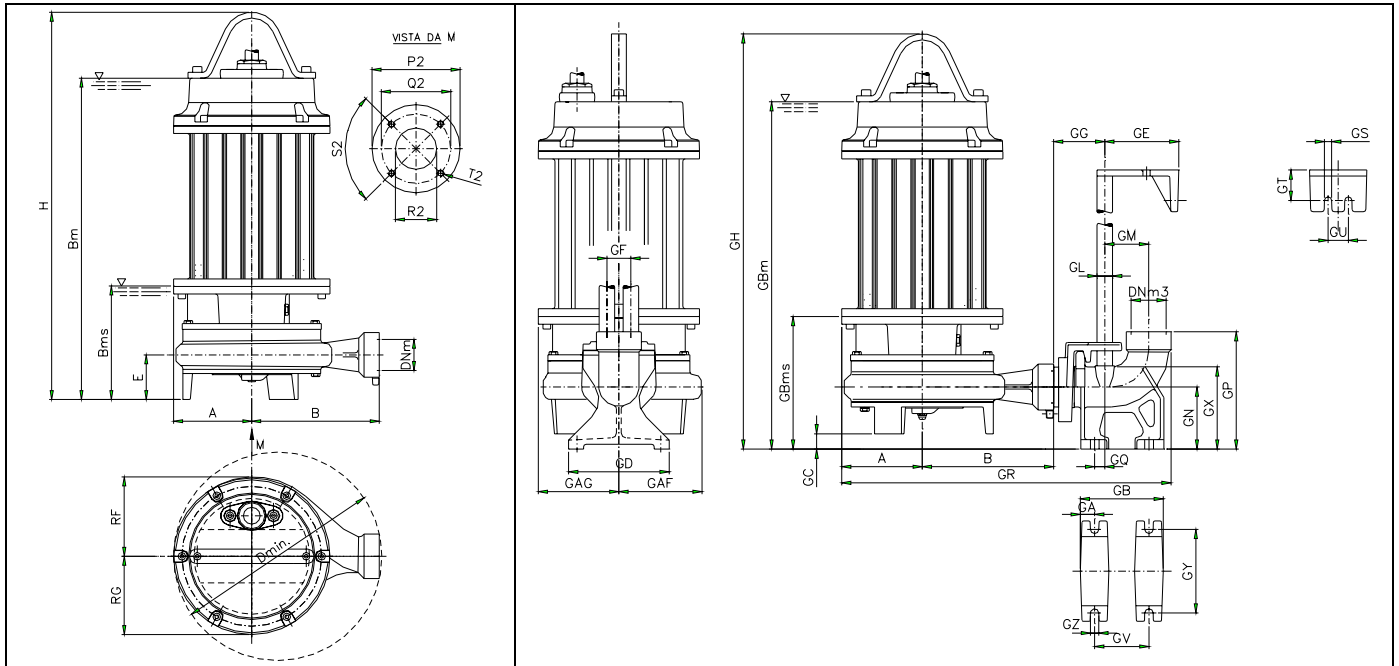

• These drawings do not represent actual product appearance. Refer to the outline on the previous page.

A	AE2	B	Bm	Bms	DA	DAF	DAG	DB	DBm	DBms	DC	DD	DE	DF	DG	DH	DL
135	125	220	556	196	25	138	135	140	583	223	27	168	124	40	84	697	¾
Dmin	DN	DNm	DNm1	DNm3	DQ	DR	DS	DT	DU	DV	DX	DY	DZ	E	GA	GAF	GAG
360	104	2	50	2	38	520	12	51	34	91	183	140	13	77	25	138	135
GB	GBm	GBms	GC	GD	GE	GF	GG	GH	GL	GM	GN	GP	GQ	GR	GS	GT	GU
140	583	223	27	168	124	40	84	697	¾	74	104	197	17	551	12	51	34
GV	GX	GY	GZ	H	K2	P2	Q2	R2	RF	RG	S2	T2	W2				
91	140	140	13	670	165	190	150	89	138	135	90	M14	18				

Number of holes in suction flange 4-DN 80 PN 6

Dimensions 'mm' except than: DL-inches DNm-inches DNm3-inches GL-inches S2-degrees	Mass: 90 Kg	Possible installations:	11-12-14-16
--	--------------------	--------------------------------	-------------

*For more information see the descriptive sections

