

# DG BluePRO 150/2/G50V A1CM

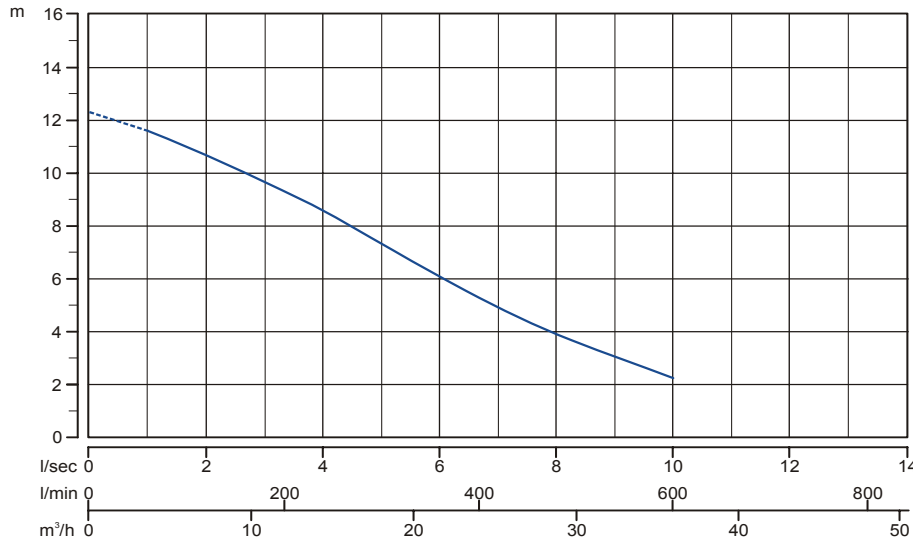

ACTUAL OUTLINE

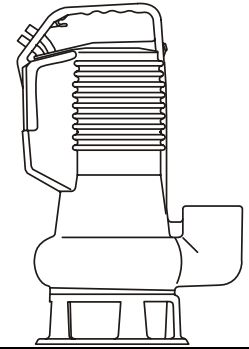

**Hydraulic type:**

vortex

**Power/poles:**

1.1 kW - 2 poles

**Outlet type:**

2" vertical

**Explosion-proof:**

Pump in NOT ex-proof version

**Free passage of solid bodies:**

50 mm

<b>ELECTRO-MECHANICAL UNIT</b>	Rated delivered power:	1.1 kW	Motor poles/revolutions:	2900 1/min – 2 poles	
	Rated absorbed power:	ND	Motor phases:	M – singlephase	
	Rated absorbed current:	7.5 A	Service:	S1 submersible or w/sleeve	
	Starting current:	ND	Motor protection:	IP 68	
	Starting torque:	ND	Insulation class (ICL):	F	
	Rated Cos Ø:	0.96	Max. Starts per hour:	20	
	Rated motor performance:	ND	Standard cable type:	5 mt-H07RN-F 3G1	
	Detailed description of series:	Submersible pumps consisting of a EN-GJL-250 cast iron electromechanical unit intended for submersible operation with 2 mechanical seals. Explosion-proof version not available.			
	Standard mechanical seals	2 mechanical silicon carbide (Viton) seals			
	Lifting:	With handle on motor cover			
	Ball bearings:	Upper and lower permanently lubricated ball bearings			
	Winding type:	Induction motor with dry winding			
	Impregnation type:	Doubly impregnated humidity-resistant winding			
Direction of rotation:	Clockwise seen from top of electric pump				
Data provided above refers to hydraulic tests carried out at: 230 Volt 50 Hz					

<b>MATERIALS</b>	<b>Mechanical unit:</b>	EN-GJL-250 cast iron	<b>Hyd. Unit, impeller:</b>	EN-GJL-250 cast iron
	<b>Shaft:</b>	X30Cr13 (AISI420) steel	<b>Bolts and Screws:</b>	INOX A2 steel
	<b>Seals (O-Ring):</b>	NBR-SBR rubber	<b>Grinder cutter:</b>	Not applicable
	<b>Cooling jacket:</b>	Not applicable	<b>Painting:</b>	Ecological epoxy vinyl

<b>LIMITS ON USE REFERENCE STANDARDS</b>	<b>Max. operating temp.:</b>	40 °C	<b>Max. sub. depth:</b>	20 m
	<b>Liquid PH:</b>	6 to 10	<b>Liquid density:</b>	1 kg/dm <sup>3</sup>
	<b>Viscosity of liquid:</b>	1 mm <sup>2</sup> /s	<b>Max. acoustic press.:</b>	< 70 dB dB
	<b>Reference standards:</b>			
	<ul style="list-style-type: none"> <li>• EN 292-1; EN 292-2; CEI EN 60529; ISO 9906; CEI EN 60034-1.</li> <li>• CEI EN 60204; UNI ISO 6009; UNI EN 1561-1563; UNI EN 10098.</li> <li>• Low voltage directive 73/23/CEE.</li> <li>• Procedures specified by Zenit Europe s.r.l. Quality System, UNI EN ISO 9001 (ISO 9001) certified, DNV n. SQ 0660-IT certified.</li> <li>• Machines directive 89/392/CEE and successive amendments thereto (directives 91/368/CEE, 93/68/CEE), electromagnetic compatibility directive 89/336/CEE</li> </ul>			

<b>SYMBOLS</b>		Product complying with European standards in force	Company Quality System complying with UNI ISO norm

<b>VARIANTS AVAILABLE</b>	<b>Electrical accessories</b>	
	<i>TC</i>	Thermistor and capacitor
	<i>TCG</i>	Thermistor, capacitor and floatswitch
	<i>TRG</i>	Thermistor, relay and floatswitch
	<b>Set of mechanical seals</b>	
	<i>2SIC</i>	2 mechanical silicon carbide (Viton) seals
<b>Cooling system / mechanical seal flushing versions</b>		
<i>N</i>	No sleeve and/or seal flushing	

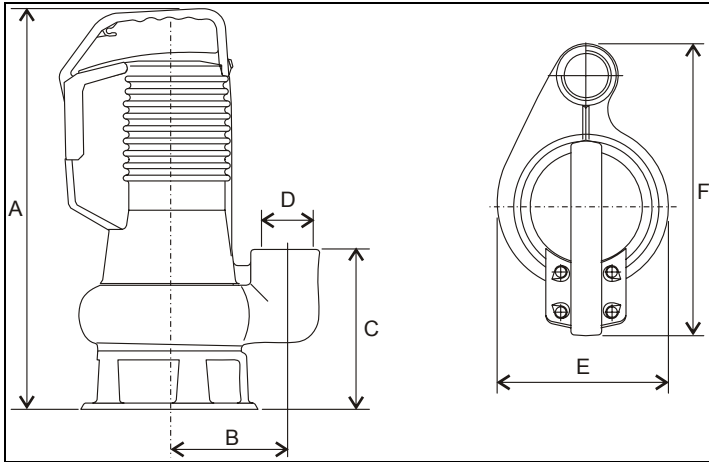

A	B	C	D	E	F
mm	mm	mm	inch	mm	mm
468	130	197	2	193	295

	<b>Mass:</b>	24 Kg
--	--------------	-------