

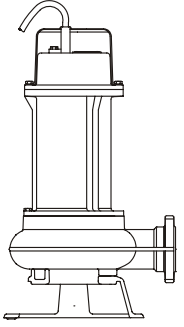
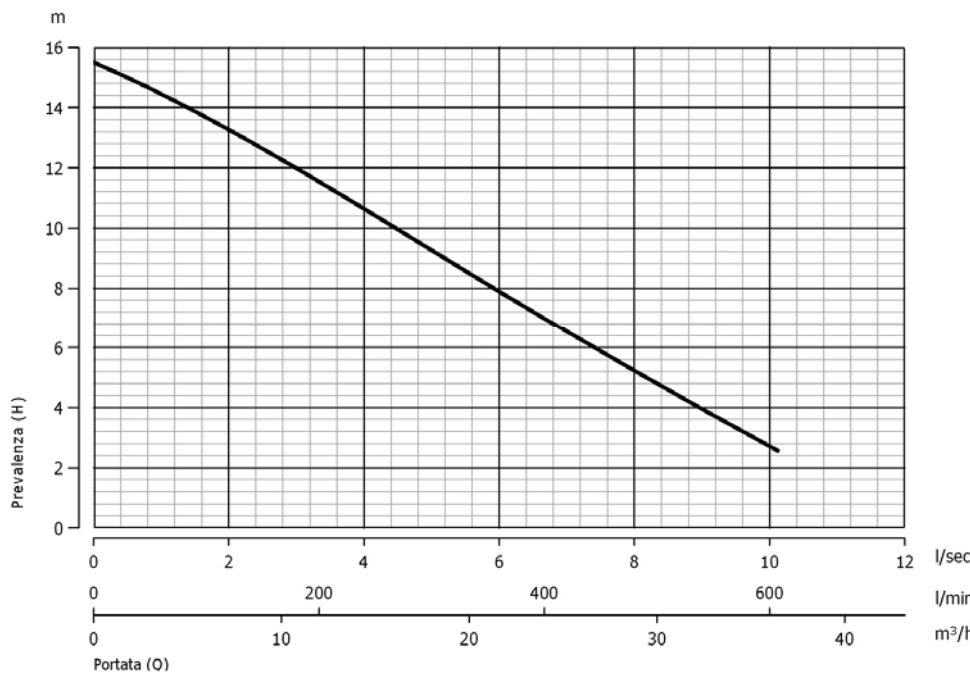

<h1>DGE 200/2/G50H A0CT-E</h1>	Hydraulic model: "A"											
	ACTUAL OUTLINE	<table border="1" style="width:100%; border-collapse: collapse;"> <tr><td style="background-color: #cccccc;">Hydraulic type:</td></tr> <tr><td>Vortex set-back impeller</td></tr> <tr><td style="background-color: #cccccc;">Power/poles:</td></tr> <tr><td>1,5 kW - 2 poles</td></tr> <tr><td style="background-color: #cccccc;">Outlet type:</td></tr> <tr><td>2" horizontal</td></tr> <tr><td style="background-color: #cccccc;">Explosion-proof:</td></tr> <tr><td>Pump in NOT ex-proof version</td></tr> <tr><td style="background-color: #cccccc;">Free passage of solid bodies:</td></tr> <tr><td>Max 38 mm</td></tr> </table>	Hydraulic type:	Vortex set-back impeller	Power/poles:	1,5 kW - 2 poles	Outlet type:	2" horizontal	Explosion-proof:	Pump in NOT ex-proof version	Free passage of solid bodies:	Max 38 mm
Hydraulic type:												
Vortex set-back impeller												
Power/poles:												
1,5 kW - 2 poles												
Outlet type:												
2" horizontal												
Explosion-proof:												
Pump in NOT ex-proof version												
Free passage of solid bodies:												
Max 38 mm												

ELECTRO-MECHANICAL UNIT	Rated delivered power:	1,5 kW	Motor poles/revolutions:	2900 1/min – 2 poles	
	Rated absorbed power:	2,01 kW	Motor phases:	T - Three-phase	
	Rated absorbed current:	3,55 A	Service:	S1 submersible or w/sleeve	
	Starting current:	Not available	Motor protection:	IP 68	
	Starting torque:	Not available	Insulation class (ICL):	F	
	Rated Cos Ø:	0,82	Max. Starts per hour:	20	
	Rated motor performance:	75%	Standard cable type:	10 mt-H07RN-F 4G1	
	Detailed description of series:	Submersible pumps consisting of a EN-GJL-250 cast iron electromechanical unit intended for submersible operation with 1 mechanical seal and 1 lip seal conventionally installed. Explosion-proof version not available.			
	Standard mechanical seals	1 mechanical graphite alumina (NBR) seal and 1 lip seal			
	Lifting:	With handle on motor cover			
Ball bearings:	Upper and lower permanently lubricated ball bearings				
Winding type:	Induction motor with dry winding				
Impregnation type:	Doubly impregnated humidity-resistant winding				
Direction of rotation:	Clockwise seen from top of electric pump				
Data provided above refers to hydraulic tests carried out at: 400 Volt 50 Hz					

MATERIALS	Mechanical unit:	EN-GJL-250 cast iron	Hyd. Unit, impeller:	EN-GJL-250 cast iron
	Shaft:	X30Cr13 (AISI420) steel	Bolts and Screws:	INOX A2 steel
	Seals (O-Ring):	NBR-SBR rubber	Grinder cutter:	Not applicable
	**Cooling jacket:	Not applicable	Painting:	Ecological epoxy vinyl
** Cooling jacket supplied upon request in series specified				

LIMITS ON USE REFERENCE STANDARDS	Max. operating temp.:	40 °C	Max. sub. depth:	20 m
	Liquid PH:	6 to 10	Liquid density:	1 kg/dm ³
	Viscosity of liquid:	1 mm ² /s	Max. acoustic press.:	< 70 dB dB
	Reference standards:			
<ul style="list-style-type: none"> • EN 292-1; EN 292-2; CEI EN 60529; ISO 9906; CEI EN 60034-1. • CEI EN 60204; UNI ISO 6009; UNI EN 1561-1563; UNI EN 10098. • Low voltage directive 73/23/CEE. • Procedures specified by Zenit Quality System, UNI EN ISO 9001 (ISO 9001) certified, DNV n. SQ 0660-IT certified. • Machines directive 89/392/CEE and successive amendments thereto (directives 91/368/CEE, 93/68/CEE), electromagnetic compatibility directive 89/336/CEE 				

SYMBOLS		Product complying with European standards in force Company Quality System complying with UNI ISO norm
----------------	---	--

VARIANTS AVAILABLE	Electrical accessories	
	<i>NAE</i>	No electrical accessories installed
	<i>T</i>	Thermistor
	<i>TRG</i>	Thermistor, relay and float
	<i>TR</i>	Thermistor and relay
	Set of mechanical seals	
	<i>ALM</i>	1 mechanical graphite alumina (NBR) seal and 1 lip seal
<i>SICM</i>	1 mechanical silicon carbide (Viton) seal and 1 lip seal	
Cooling system / mechanical seal flushing versions		
<i>N</i>	No sleeve and/or seal flushing	

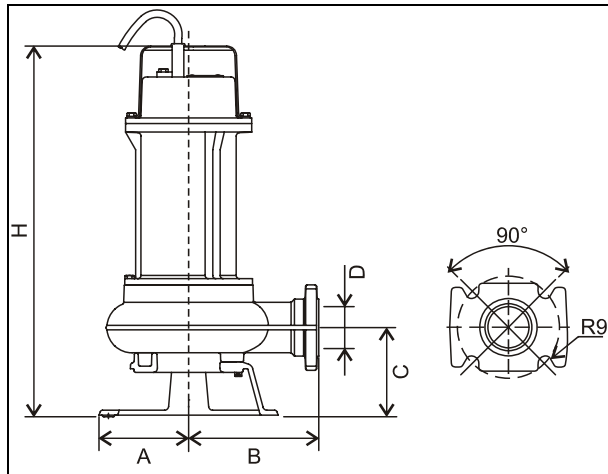

A mm	B mm	C mm	D inch	H mm
110	160	110	2	455

Mass:	21 Kg
--------------	-------