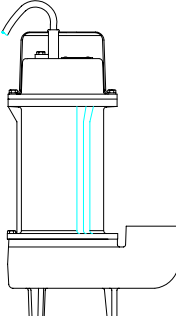
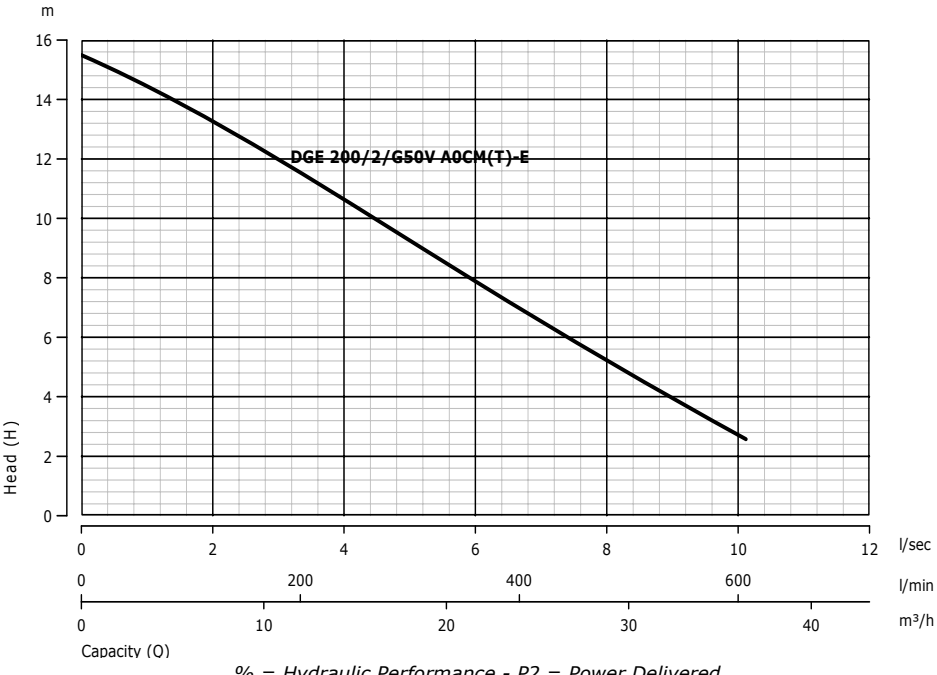

<h1>DGE 200/2/G50V A0CT-E</h1>	Hydraulic model: "A"	
 <p style="text-align: center;">% = Hydraulic Performance - P2 = Power Delivered</p>		ACTUAL OUTLINE Hydraulic type: Vortex set-back impeller* Power/poles: 1,5 kW - 2 Poles Outlet type: 2" vertical gas threaded opening Explosion-proof: Pump in NOT ex-proof version Free passage of solid bodies: Max 38 mm

ELECTRO-MECHANICAL UNIT	Rated delivered power:	1,5 kW	Motor poles/revolutions:	2900 1/min - 2Poles
	Rated absorbed power:	2,01 kW	Motor phases:	T - Three-phase
	Rated absorbed current:	3,55 A	Service:	S1 submersible or w/sleeve
	Starting current:	Not available	Motor protection:	IP 68
	Starting torque:	Not available	Insulation class (ICL):	F
	Rated Cos Ø:	0,82	Max. Starts per hour:	20
	Rated motor performance:	75%	Standard cable type:	10 mt-H07RN-F 4G1
	Detailed description of series:	Submersible pumps consisting of a EN-GJL-250 cast iron electromechanical unit intended for submersible operation with 1 mechanical seal and 1 lip seal conventionally installed. Explosion-proof version not available.*		
	Standard mechanical seals	1 mechanical graphite alumina (NBR) seal and 1 lip seal		
	Lifting:	With handle on motor cover		
Ball bearings:	Upper and lower permanently lubricated ball bearings			
Winding type:	Induction motor with dry winding			
Impregnation type:	Doubly impregnated humidity-resistant winding			
Direction of rotation:	Clockwise seen from top of electric pump			
Data provided above refers to hydraulic tests carried out at: 400 Volt 50 Hz				

MATERIALS	Mechanical unit:	EN-GJL-250 cast iron	Hyd. Unit, impeller:	EN-GJL-250 cast iron
	Shaft:	X30Cr13 (AISI420) steel	Bolts and Screws:	INOX A2 steel
	Seals (O-Ring):	NBR-SBR rubber	Grinder cutter:	Not applicable
	**Cooling jacket:	Not applicable	Painting:	Ecological epoxy vinyl
** Cooling jacket supplied upon request in series specified				

LIMITS ON USE REFERENCE STANDARDS	Max. operating temp.:	40 °C	Max. sub. depth:	20 m
	Liquid PH:	6 to 10	Liquid density:	1 kg/dm ³
	Viscosity of liquid:	1 mm ² /s	Max. acoustic press.:	< 70 dB dB
	Reference standards:			
	<ul style="list-style-type: none"> • EN 292-1; EN 292-2; CEI EN 60529; ISO 9906; CEI EN 60034-1. • CEI EN 60204; UNI ISO 6009; UNI EN 1561-1563; UNI EN 10098. • Low voltage directive 73/23/CEE. • Procedures specified by Zenit S.p.a. Quality System, UNI EN ISO 9001 (ISO 9001) certified, DNV n. SQ 0660-IT certified. • Machines directive 89/392/CEE and successive amendments thereto (directives 91/368/CEE, 93/68/CEE), electromagnetic compatibility directive 89/336/CEE 			

SYMBOLS		Product complying with European standards in force Company Quality System complying with UNI ISO norm
----------------	---	--

VARIANTS AVAILABLE	Electrical accessories	
	NAE	No electrical accessories installed
	T	Thermistor
	TRG	Thermistor, relay and float
	TR	Thermistor and relay
	Set of mechanical seals	
	ALM	1 mechanical graphite alumina (NBR) seal and 1 lip seal
	SICM	1 mechanical silicon carbide (Viton) seal and 1 lip seal
	Cooling system / mechanical seal flushing versions*	
	N	No sleeve and/or seal flushing

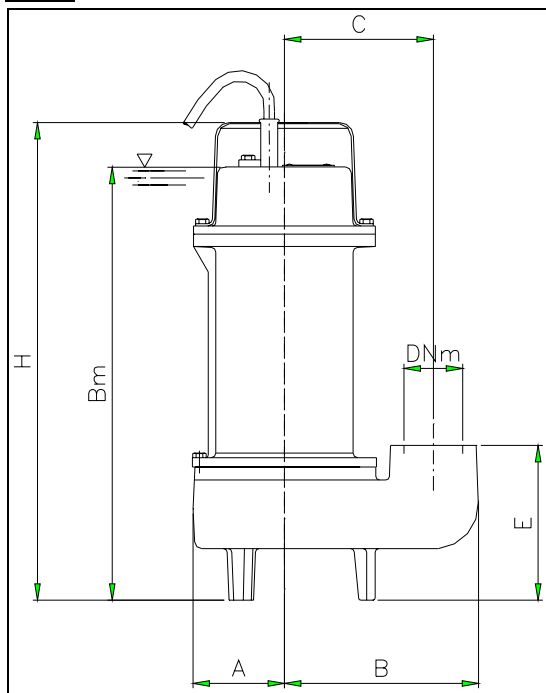

A	B	Bm	C	DNm	DNm4	E
80	166	372	127	2	2	132
EB	ED	EE	EF	EG	EP	EQ
240	2	87	98	278	70	75
ER	H	H4	L4	M4		
54	410	18	165	125		

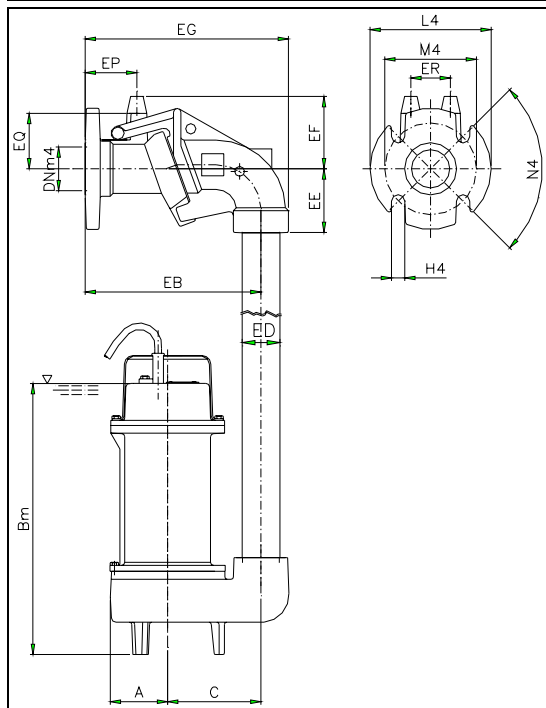

• These drawings do not represent actual product appearance. Refer to the outline on the previous page.

Dimensions 'mm' except than: DNm-inches DNm4-inches ED-inches	Mass: 21 Kg	Possible installations:	I1-I2-I3
---	--------------------	--------------------------------	----------

*For more information see the descriptive sections