

DR BluePRO 150/2/G50V A1CT

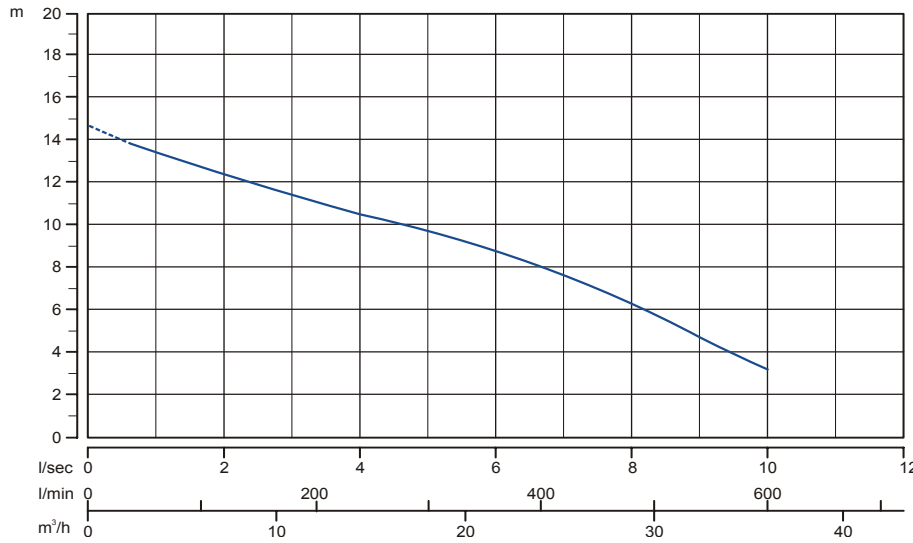

ACTUAL OUTLINE

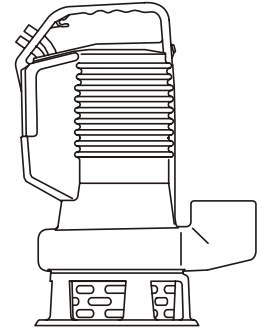

Hydraulic type:

Drainage

Power/poles:

1.1 kW - 2 poles

Outlet type:

2" vertical

Explosion-proof:

Pump in NOT ex-proof version

Free passage of solid bodies:

30x10 mm

ELECTRO-MECHANICAL UNIT

Rated delivered power:	1.1 kW	Motor poles/revolutions:	2900 1/min – 2 poles
Rated absorbed power:	ND	Motor phases:	T - threephase
Rated absorbed current:	3.2 A	Service:	S1 submersible or w/sleeve
Starting current:	ND	Motor protection:	IP 68
Starting torque:	ND	Insulation class (ICL):	F
Rated Cos Ø:	0.72	Max. Starts per hour:	20
Rated motor performance:	ND	Standard cable type:	5 mt-H07RN-F 3G1
Detailed description of series:	Submersible pumps consisting of a EN-GJL-250 cast iron electromechanical unit intended for submersible operation with 2 mechanical seals. Explosion-proof version not available.		
Standard mechanical seals	2 mechanical silicon carbide (Viton) seals		
Lifting:	With handle on motor cover		
Ball bearings:	Upper and lower permanently lubricated ball bearings		
Winding type:	Induction motor with dry winding		
Impregnation type:	Doubly impregnated humidity-resistant winding		
Direction of rotation:	Clockwise seen from top of electric pump		
Data provided above refers to hydraulic tests carried out at: 400 Volt 50 Hz			

MATERIALS

Mechanical unit:	EN-GJL-250 cast iron	Hyd. Unit, impeller:	EN-GJL-250 cast iron
Shaft:	X30Cr13 (AISI420) steel	Bolts and Screws:	INOX A2 steel
Seals (O-Ring):	NBR-SBR rubber	Grinder cutter:	Not applicable
Cooling jacket:	Not applicable	Painting:	Ecological epoxy vinyl

**LIMITS ON USE
REFERENCE STANDARDS**

Max. operating temp.:	40 °C	Max. sub. depth:	20 m
Liquid PH:	6 to 10	Liquid density:	1 kg/dm ³
Viscosity of liquid:	1 mm ² /s	Max. acoustic press.:	< 70 dB dB
Reference standards:			
<ul style="list-style-type: none"> • EN 292-1; EN 292-2; CEI EN 60529; ISO 9906; CEI EN 60034-1. • CEI EN 60204; UNI ISO 6009; UNI EN 1561-1563; UNI EN 10098. • Low voltage directive 73/23/CEE. • Procedures specified by Zenit Europe s.r.l. Quality System, UNI EN ISO 9001 (ISO 9001) certified, DNV n. SQ 0660-IT certified. • Machines directive 89/392/CEE and successive amendments thereto (directives 91/368/CEE, 93/68/CEE), electromagnetic compatibility directive 89/336/CEE 			

SYMBOLS



Product complying with European standards in force

Company Quality System complying with UNI ISO norm



VARIANTS AVAILABLE	Electrical accessories	
	<i>TC</i>	Thermistor and capacitor
	<i>TCG</i>	Thermistor, capacitor and floatswitch
	<i>TRG</i>	Thermistor, relay and floatswitch
	Set of mechanical seals	
	<i>2SIC</i>	2 mechanical silicon carbide (Viton) seals
Cooling system / mechanical seal flushing versions		
<i>N</i>	No sleeve and/or seal flushing	

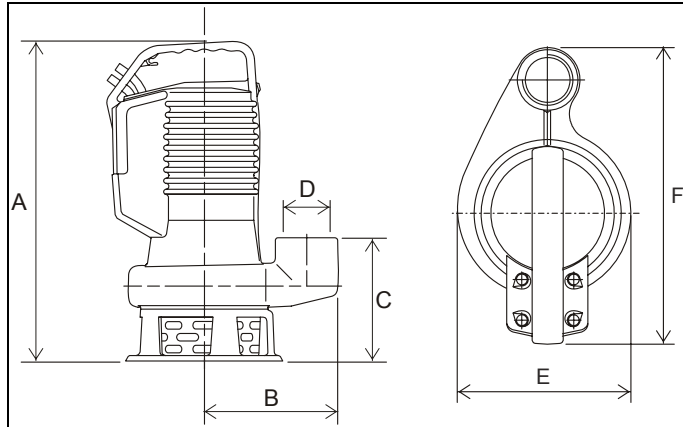

A mm	B mm	C mm	D inch	E mm	F mm
422	130	170	2	175	295

	Mass:	23 Kg
--	--------------	-------