

ELECTRO-MECHANICAL UNIT	Rated delivered power:	1.8 kW	Motor poles/revolutions:	2900 1/min – 2 Poles
	Rated absorbed power:	2.2 kW	Motor phases:	T - three phase
	Rated absorbed current:	4.3 A	Service:	S1 submersed or with cooling system -
	Starting current:	17.2 A	Motor protection:	IP 68
	Starting torque:	13,62 Nm	Insulation class (ICL):	H
	Rated Cos Ø:	0,9	Max. Starts per hour:	20
	Rated motor performance:	69%	Standard cable type:	H07RN-F 4G1,5 + 3x1 (10 m)
	Detailed description of series:	Submersible pump made of EN-GJL-250 cast iron, suitable for submersible operation, with 2 mechanical seals installed in an inspectable oil chamber. Dry motor.		
	Standard mechanical seals	2 Silicon Carbide mechanical seals in oil chamber		
	Lifting:	With handle on motor cover		
	Ball bearings:	Upper and lower permanently lubricated ball bearings		
	Winding type:	Induction motor with dry winding and manual thermal protection		
Impregnation type:	Doubly impregnated humidity-resistant winding			
Direction of rotation:	Clockwise seen from top of electric pump			
Data provided above refers to hydraulic tests carried out at: 400 Volt 50 Hz				

MATERIALS	Mechanical unit:	EN-GJL-250 cast-iron	Hyd. Unit, impeller:	EN-GJL-250 cast-iron
	Shaft:	AISI 420	Bolts and Screws:	INOX A2-70
	Seals (O-Ring):	NBR rubber	Grinder cutter:	X102 CrMo17 KU
	**Cooling jacket:	AISI 304 stainless steel	Painting:	Ecological epoxy vinyl
** Cooling jacket supplied upon request in series specified				

LIMITS ON USE REFERENCE STANDARDS	Max. operating temp.:	40° C	Max. sub. depth:	30 m
	Liquid PH:	6 ÷ 14	Liquid density:	1 Kg/dm3
	Viscosity of liquid:	1 mm2/s	Max. acoustic press.:	< 70 dB(A)
	Reference standards:			
<ul style="list-style-type: none"> ▪ MACHINE DIRECTIVE 89/392/EEC and subsequent amendments (directives: D1/368/EEC, 93/68/EEC); ▪ LOW VOLTAGE DIRECTIVE 73/ 23/ EEC; ▪ ELECTROMAGNETIC COMPATIBILITY DIRECTIVE 89/336/EEC; ▪ EN292-1; EN 292; UNI EN 414 CEI EN 60529; CEI EN 60034-1; CEI EN 60034-2; CEI EN 60335-1; CEI EN 60335-2-41; UNI EN 9906; CEI EN 60204; UNI EN 1561; UNI EN 1563; UNI EN 614; ▪ Procedures required by the Zenit S.r.l. Quality System. UNI EN 9001 certificate (ISO 9001), DNV certificate No. CERT-00660-95-AQ-BOLSINCERT. 				

VARIANTS AVAILABLE	Electrical accessories	
	T - TS	Thermostat - Thermostat and probe
	Set of mechanical seals	
	2SIC	2 Silicon Carbide mechanical seals in oil chamber
Cooling system / mechanical seal flushing versions*		
N - CC	No cooling system available - Cooling system using treated liquid	

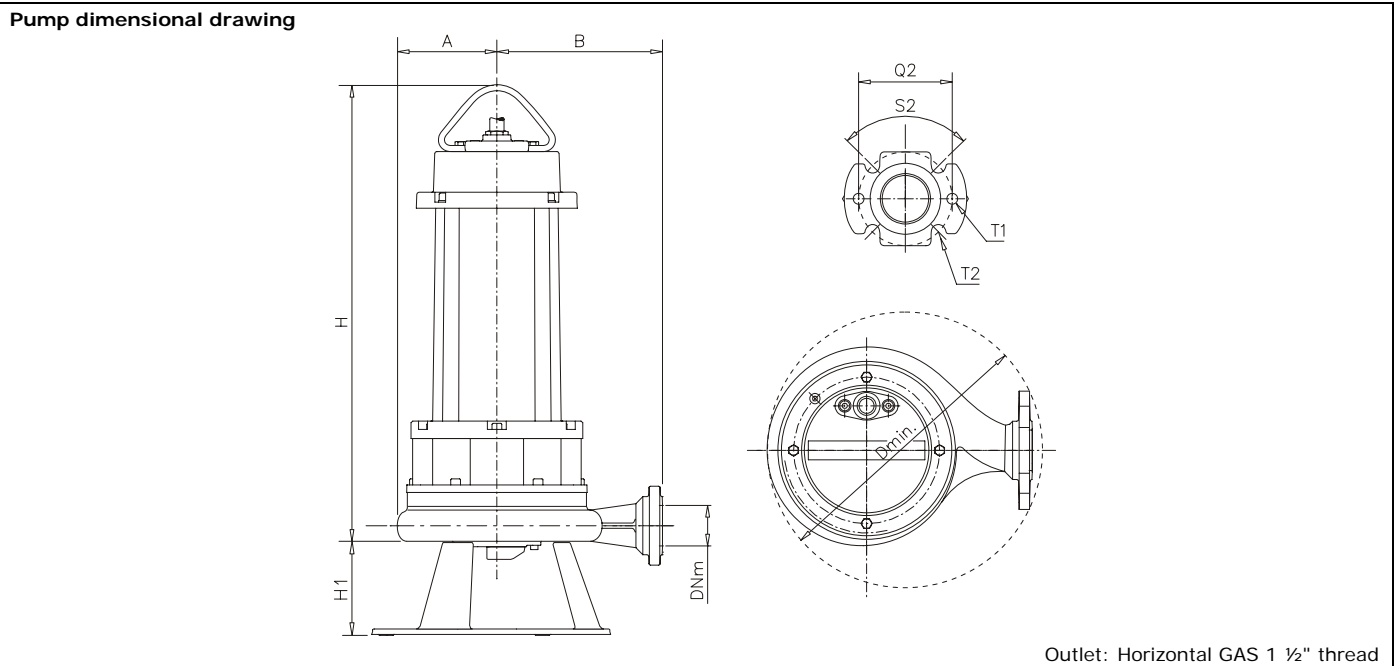

	A (mm)	B (mm)	Dmin (mm)	DNm (inch)	H (mm)	H1 (mm)	Q2 (mm)	S2 (mm)	DV (mm)	T1	T2 (mm)	
GRN 250/2/G40H A1DT	107	160	546	GAS 1 1/2	498	124	150	90	91	M12	14	

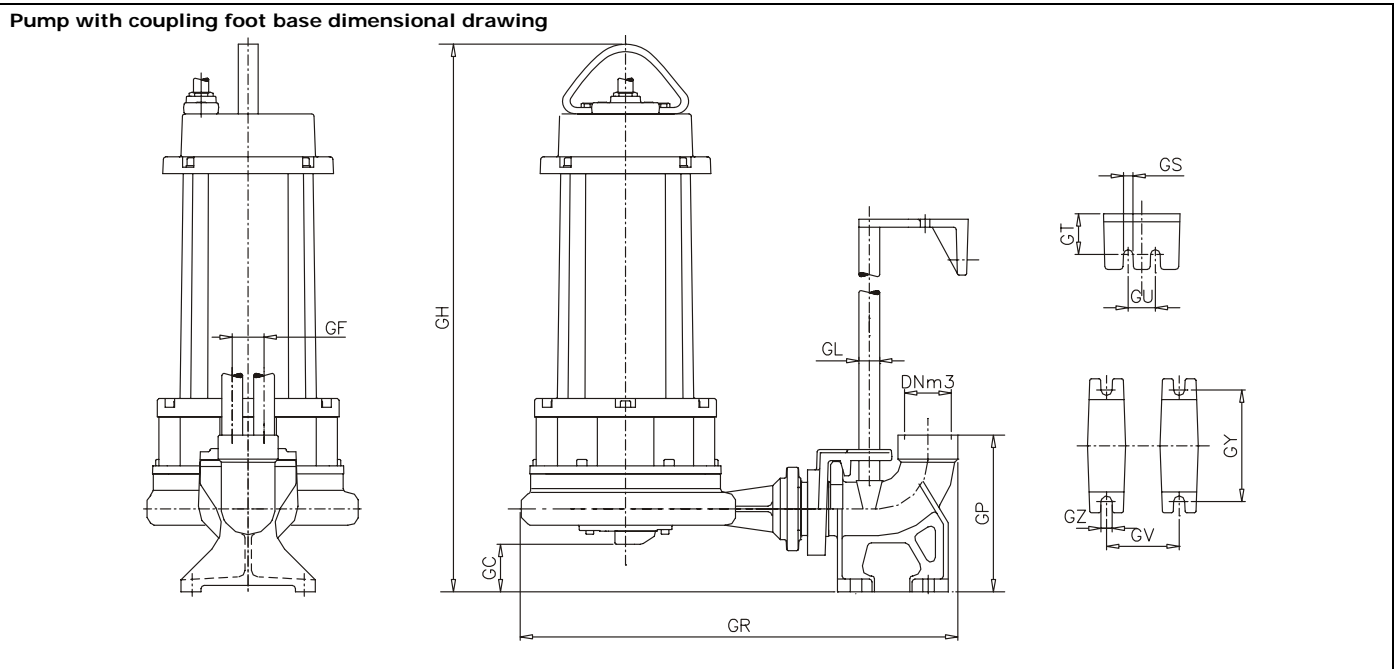

	GC (mm)	GF (mm)	GH (mm)	GL (inch)	DNm3 (inch)	GP (mm)	GR (mm)	GS (mm)
GRN 250/2/G40H A1DT	61	40	560	3/4	GAS 2	216	482	12
	GT (mm)	GU (mm)	GV (mm)	GY (mm)	GZ (mm)			
	51	34	91	140	14			

Mass: 44 Kg

