

<b>ELECTRO-MECHANICAL UNIT</b>	Rated delivered power:	3.0 kW	Motor poles/revolutions:	2900 1/min – 2 Poles
	Rated absorbed power:	4.0 kW	Motor phases:	T - three phase
	Rated absorbed current:	6.7 A	Service:	S1 submersed or with cooling system -
	Starting current:	29.7 A	Motor protection:	IP 68
	Starting torque:	22,74 Nm	Insulation class (ICL):	H
	Rated Cos Ø:	0,86	Max. Starts per hour:	20
	Rated motor performance:	75%	Standard cable type:	H07RN-F 4G1,5 + 3x1 (10 m)
	Detailed description of series:	Submersible pump made of EN-GJL-250 cast iron, suitable for submersible operation, with 2 mechanical seals installed in an inspectable oil chamber. Dry motor.		
	Standard mechanical seals	2 Silicon Carbide mechanical seals in oil chamber		
	Lifting:	With handle on motor cover		
Ball bearings:	Upper and lower permanently lubricated ball bearings			
Winding type:	Induction motor with dry winding and manual thermal protection			
Impregnation type:	Doubly impregnated humidity-resistant winding			
Direction of rotation:	Clockwise seen from top of electric pump			
Data provided above refers to hydraulic tests carried out at: 400 Volt 50 Hz				

<b>MATERIALS</b>	<b>Mechanical unit:</b>	EN-GJL-250 cast-iron	<b>Hyd. Unit, impeller:</b>	EN-GJL-250 cast-iron
	<b>Shaft:</b>	AISI 420	<b>Bolts and Screws:</b>	INOX A2-70
	<b>Seals (O-Ring):</b>	NBR rubber	<b>Grinder cutter:</b>	X102 CrMo17 KU
	<b>**Cooling jacket:</b>	AISI 304 stainless steel	<b>Painting:</b>	Ecological epoxy vinyl
** Cooling jacket supplied upon request in series specified				

<b>LIMITS ON USE REFERENCE STANDARDS</b>	<b>Max. operating temp.:</b>	40° C	<b>Max. sub. depth:</b>	30 m
	<b>Liquid PH:</b>	6 ÷ 14	<b>Liquid density:</b>	1 Kg/dm3
	<b>Viscosity of liquid:</b>	1 mm2/s	<b>Max. acoustic press.:</b>	< 70 dB(A)
	<b>Reference standards:</b>			
<ul style="list-style-type: none"> <li>▪ MACHINE DIRECTIVE 89/392/EEC and subsequent amendments (directives: D1/368/EEC, 93/68/EEC);</li> <li>▪ LOW VOLTAGE DIRECTIVE 73/ 23/ EEC;</li> <li>▪ ELECTROMAGNETIC COMPATIBILITY DIRECTIVE 89/336/EEC;</li> <li>▪ EN292-1; EN 292; UNI EN 414 CEI EN 60529; CEI EN 60034-1; CEI EN 60034-2; CEI EN 60335-1; CEI EN 60335-2-41; UNI EN 9906; CEI EN 60204; UNI EN 1561; UNI EN 1563; UNI EN 614;</li> <li>▪ Procedures required by the Zenit S.r.l. Quality System. UNI EN 9001 certificate (ISO 9001), DNV certificate No. CERT-00660-95-AQ-BOLSINCERT.</li> </ul>				



<b>VARIANTS AVAILABLE</b>	<b>Electrical accessories</b>	
	T - TS	Thermostat - Thermostat and probe
	<b>Set of mechanical seals</b>	
	2SIC	2 Silicon Carbide mechanical seals in oil chamber
<b>Cooling system / mechanical seal flushing versions*</b>		
N - CC	No cooling system available - Cooling system using treated liquid	

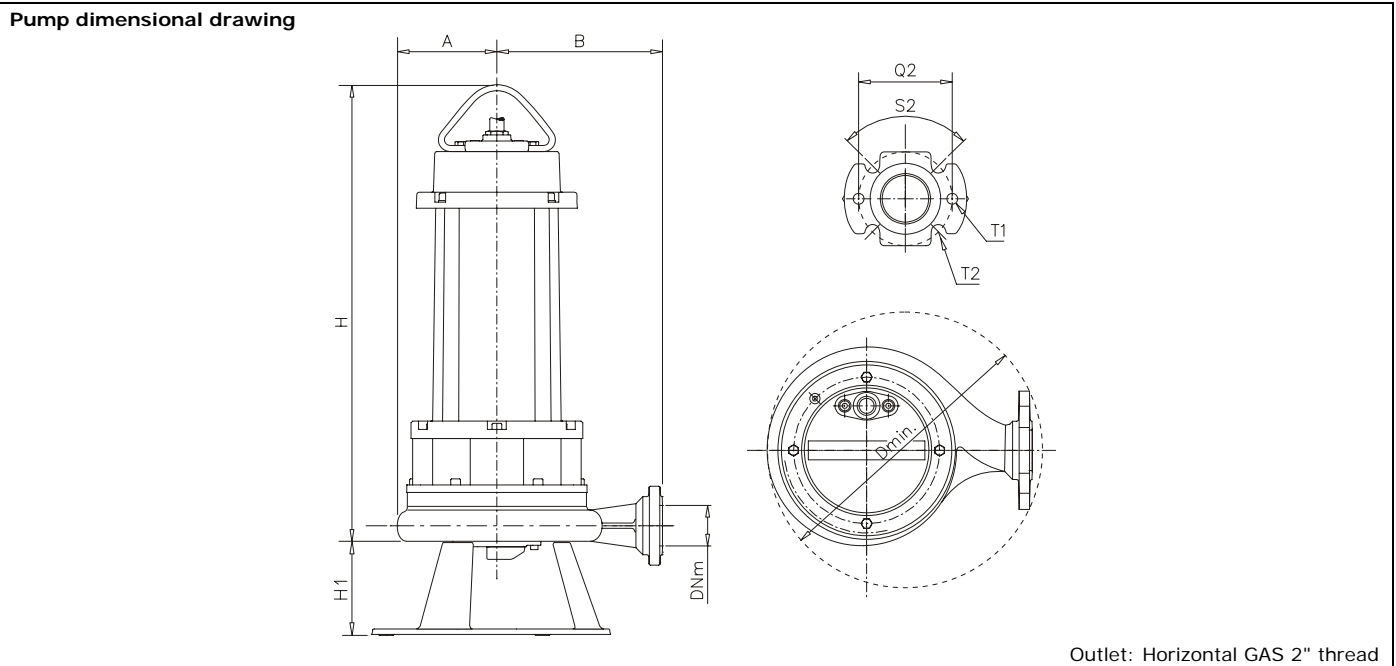

	A (mm)	B (mm)	Dmin (mm)	DNm (inch)	H (mm)	H1 (mm)	Q2 (mm)	S2 (mm)	DV (mm)	T1	T2 (mm)	
<b>GRN 400/2/G50H A1FT</b>	132	220	360	GAS 2	629	124	150	90	91	M12	14	

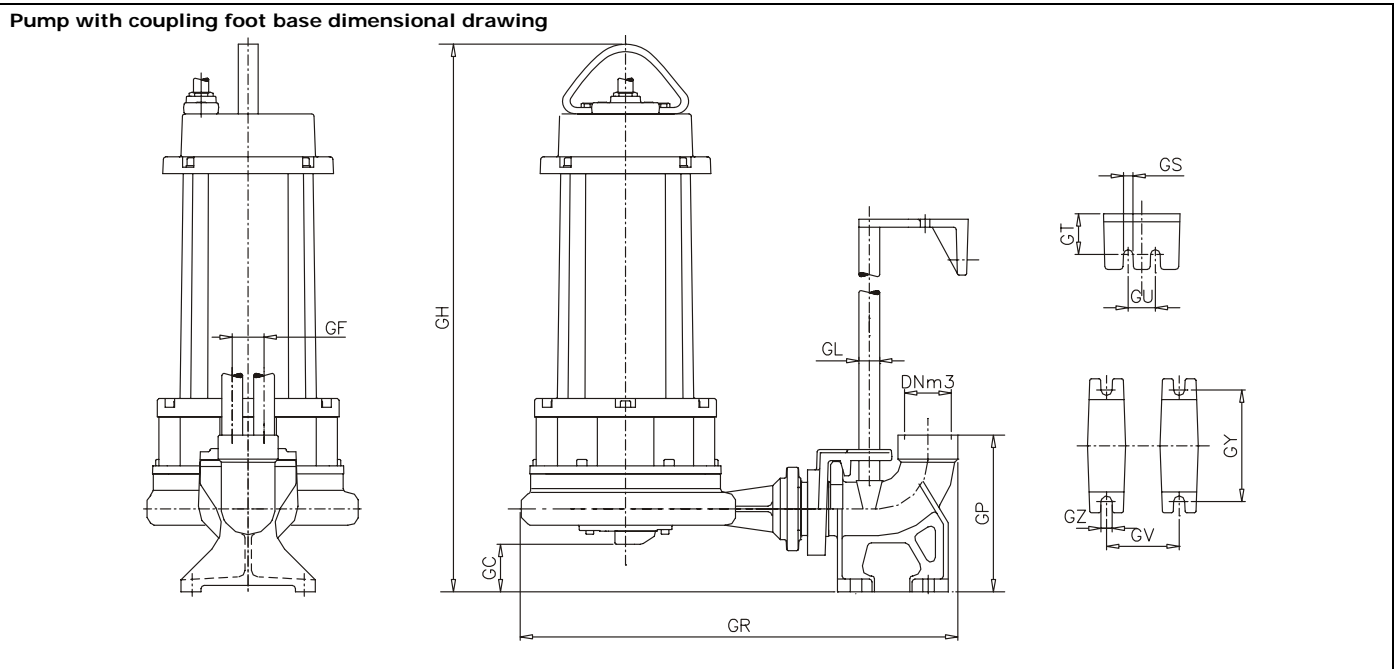

	GC (mm)	GF (mm)	GH (mm)	GL (inch)	DNm3 (inch)	GP (mm)	GR (mm)	GS (mm)
<b>GRN 400/2/G50H A1FT</b>	58	40	687	¾	GAS 2	197	548	12
	GT (mm)	GU (mm)	GV (mm)	GY (mm)	GZ (mm)			
	51	34	91	140	13			

**Mass:** 69 Kg

