

<b>ELECTRO-MECHANICAL UNIT</b>	Rated delivered power:	2.2 kW	Motor poles/revolutions:	2900 1/min – 2 Poles
	Rated absorbed power:	2.8 kW	Motor phases:	T - three phase
	Rated absorbed current:	5.1 A	Service:	S1 submersed or with cooling system -
	Starting current:	22.2 A	Motor protection:	IP 68
	Starting torque:	16,66 Nm	Insulation class (ICL):	H
	Rated Cos Ø:	0,79	Max. Starts per hour:	20
	Rated motor performance:	79%	Standard cable type:	H07RN-F 4G1,5 + 3x1 (10 m)
	Detailed description of series:	Submersible pump made of EN-GJL-250 cast iron, suitable for submersible operation, with 2 mechanical seals installed in an inspectable oil chamber. Dry motor.		
	Standard mechanical seals	2 Silicon Carbide mechanical seals in oil chamber		
	Lifting:	With handle on motor cover		
Ball bearings:	Upper and lower permanently lubricated ball bearings			
Winding type:	Induction motor with dry winding and manual thermal protection			
Impregnation type:	Doubly impregnated humidity-resistant winding			
Direction of rotation:	Clockwise seen from top of electric pump			
Data provided above refers to hydraulic tests carried out at: 400 Volt 50 Hz				

<b>MATERIALS</b>	<b>Mechanical unit:</b>	EN-GJL-250 cast-iron	<b>Hyd. Unit, impeller:</b>	EN-GJL-250 cast-iron
	<b>Shaft:</b>	AISI 420	<b>Bolts and Screws:</b>	INOX A2-70
	<b>Seals (O-Ring):</b>	NBR rubber	<b>Grinder cutter:</b>	-
	<b>**Cooling jacket:</b>	AISI 304 stainless steel	<b>Painting:</b>	Ecological epoxy vinyl
** Cooling jacket supplied upon request in series specified				

<b>LIMITS ON USE REFERENCE STANDARDS</b>	<b>Max. operating temp.:</b>	40° C	<b>Max. sub. depth:</b>	30 m
	<b>Liquid PH:</b>	6 ÷ 14	<b>Liquid density:</b>	1 Kg/dm3
	<b>Viscosity of liquid:</b>	1 mm2/s	<b>Max. acoustic press.:</b>	< 70 dB(A)
	<b>Reference standards:</b>			
<ul style="list-style-type: none"> <li>▪ MACHINE DIRECTIVE 89/392/EEC and subsequent amendments (directives: D1/368/EEC, 93/68/EEC);</li> <li>▪ LOW VOLTAGE DIRECTIVE 73/ 23/ EEC;</li> <li>▪ ELECTROMAGNETIC COMPATIBILITY DIRECTIVE 89/336/EEC;</li> <li>▪ EN292-1; EN 292; UNI EN 414 CEI EN 60529; CEI EN 60034-1; CEI EN 60034-2; CEI EN 60335-1; CEI EN 60335-2-41; UNI EN 9906; CEI EN 60204; UNI EN 1561; UNI EN 1563; UNI EN 614;</li> <li>▪ Procedures required by the Zenit S.r.l. Quality System. UNI EN 9001 certificate (ISO 9001), DNV certificate No. CERT-00660-95-AQ-BOLSINCERT.</li> </ul>				



<b>VARIANTS AVAILABLE</b>	<b>Electrical accessories</b>	
	T - TS	Thermostat - Thermostat and probe
	<b>Set of mechanical seals</b>	
	2SIC	2 Silicon Carbide mechanical seals in oil chamber
<b>Cooling system / mechanical seal flushing versions*</b>		
N - CC	No cooling system available - Cooling system using treated liquid	

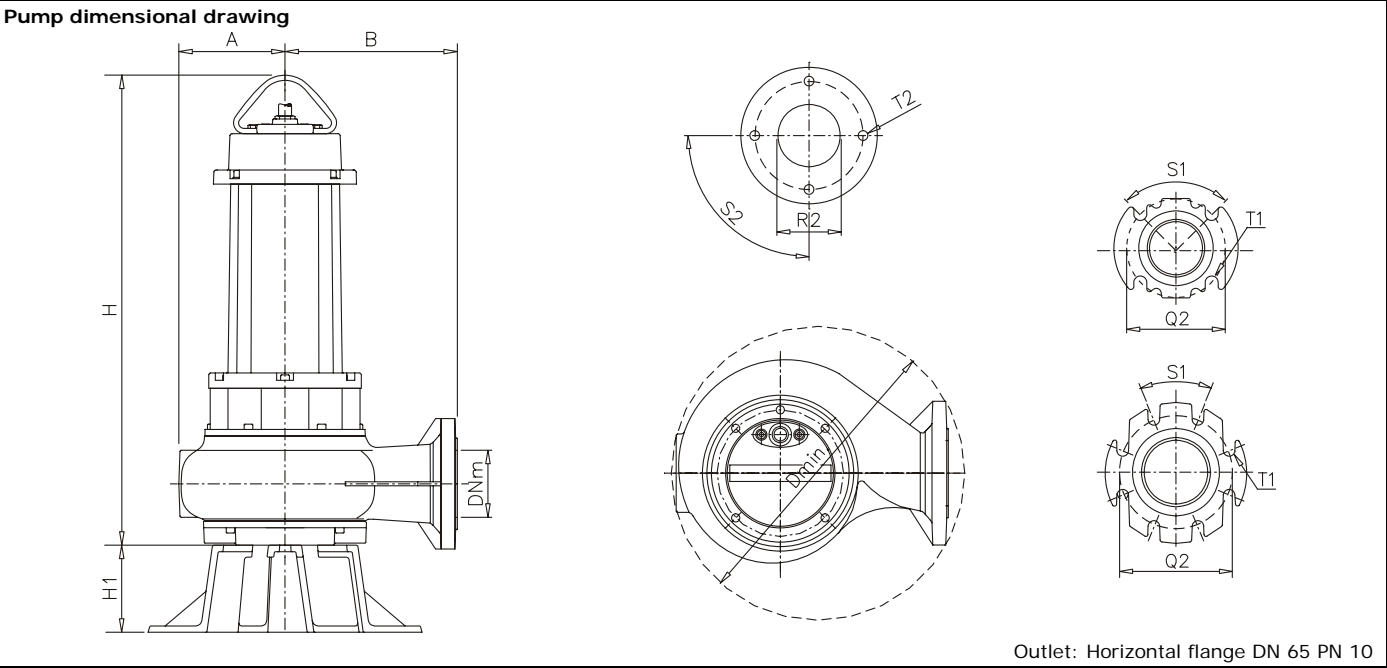

	A (mm)	B (mm)	Dmin (mm)	DNm (mm)	H (mm)	H1 (mm)	Q2 (mm)	R2 (mm)	S1 (°)	S2 (°)	T1 (mm)	T2
<b>MAN 300/2/65 A1DT</b>	136	208	373	65	552	124	145	65	90	90	18	M12

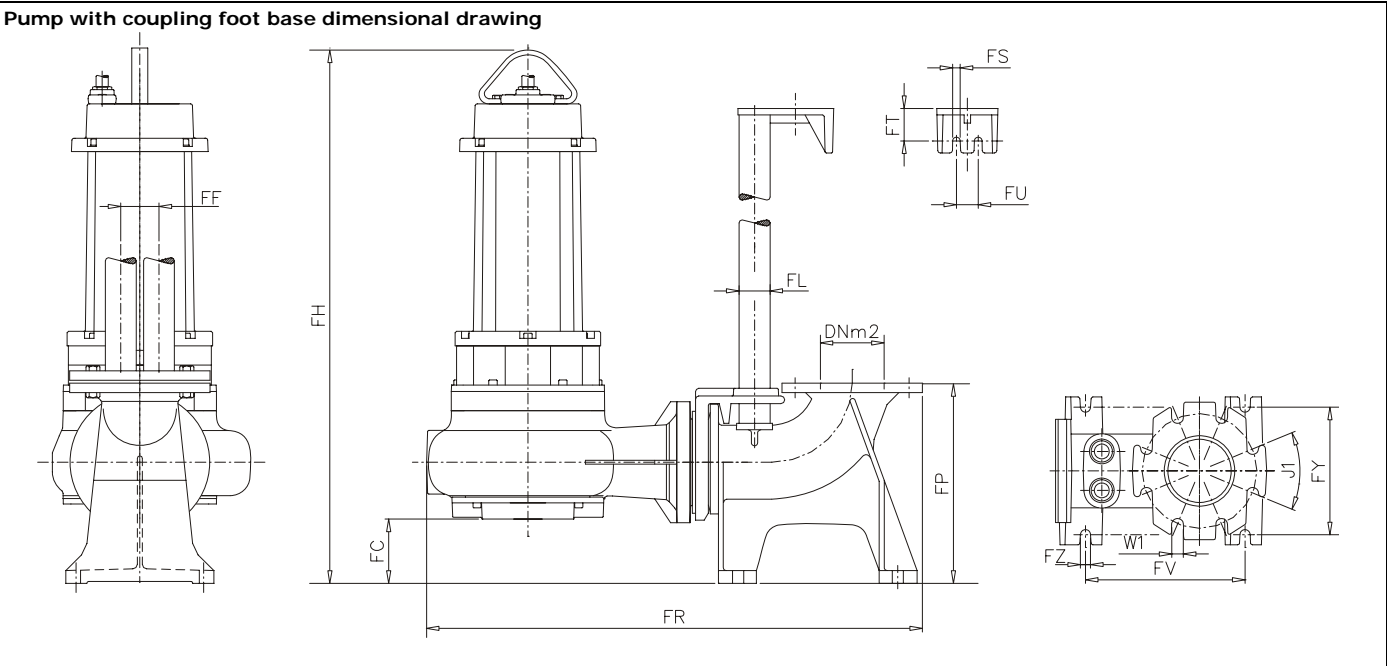

	DNm2 (mm)	FC (mm)	FF (mm)	FH (mm)	FL (inch)	FR (mm)	FS (mm)	FT (mm)
<b>MAN 300/2/65 A1DT</b>	65	105	61	657	1 ½	629	12	51
	FU (mm)	FV (mm)	FY (mm)	FZ (mm)	J1 (°)	W1 (mm)		
	34	235	80	14	90	18		

**Mass:** 58 Kg

