

ELECTRO-MECHANICAL UNIT	Rated delivered power:	2.2 kW	Motor poles/revolutions:	2900 1/min – 2 Poles
	Rated absorbed power:	2.8 kW	Motor phases:	T - three phase
	Rated absorbed current:	5.1 A	Service:	S1 submersed or with cooling system -
	Starting current:	22.2 A	Motor protection:	IP 68
	Starting torque:	16,66 Nm	Insulation class (ICL):	H
	Rated Cos Ø:	0,79	Max. Starts per hour:	20
	Rated motor performance:	79%	Standard cable type:	H07RN-F 4G1,5 + 3x1 (10 m)
	Detailed description of series:	Submersible pump made of EN-GJL-250 cast iron, suitable for submersible operation, with 2 mechanical seals installed in an inspectable oil chamber. Dry motor.		
	Standard mechanical seals	2 Silicon Carbide mechanical seals in oil chamber		
	Lifting:	With handle on motor cover		
Ball bearings:	Upper and lower permanently lubricated ball bearings			
Winding type:	Induction motor with dry winding and manual thermal protection			
Impregnation type:	Doubly impregnated humidity-resistant winding			
Direction of rotation:	Clockwise seen from top of electric pump			
Data provided above refers to hydraulic tests carried out at: 400 Volt 50 Hz				

MATERIALS	Mechanical unit:	EN-GJL-250 cast-iron	Hyd. Unit, impeller:	EN-GJL-250 cast-iron
	Shaft:	AISI 420	Bolts and Screws:	INOX A2-70
	Seals (O-Ring):	NBR rubber	Grinder cutter:	-
	**Cooling jacket:	AISI 304 stainless steel	Painting:	Ecological epoxy vinyl
** Cooling jacket supplied upon request in series specified				

LIMITS ON USE REFERENCE STANDARDS	Max. operating temp.:	40° C	Max. sub. depth:	30 m
	Liquid PH:	6 ÷ 14	Liquid density:	1 Kg/dm3
	Viscosity of liquid:	1 mm2/s	Max. acoustic press.:	< 70 dB(A)
	Reference standards:			
<ul style="list-style-type: none"> ▪ MACHINE DIRECTIVE 89/392/EEC and subsequent amendments (directives: D1/368/EEC, 93/68/EEC); ▪ LOW VOLTAGE DIRECTIVE 73/ 23/ EEC; ▪ ELECTROMAGNETIC COMPATIBILITY DIRECTIVE 89/336/EEC; ▪ EN292-1; EN 292; UNI EN 414 CEI EN 60529; CEI EN 60034-1; CEI EN 60034-2; CEI EN 60335-1; CEI EN 60335-2-41; UNI EN 9906; CEI EN 60204; UNI EN 1561; UNI EN 1563; UNI EN 614; ▪ Procedures required by the Zenit S.r.l. Quality System. UNI EN 9001 certificate (ISO 9001), DNV certificate No. CERT-00660-95-AQ-BOLSINCERT. 				

VARIANTS AVAILABLE	Electrical accessories	
	<i>T - TS</i>	<i>Thermostat - Thermostat and probe</i>
	Set of mechanical seals	
	<i>2SIC</i>	<i>2 Silicon Carbide mechanical seals in oil chamber</i>
Cooling system / mechanical seal flushing versions*		
<i>N - CC</i>	<i>No cooling system available - Cooling system using treated liquid</i>	

Pump dimensional drawing

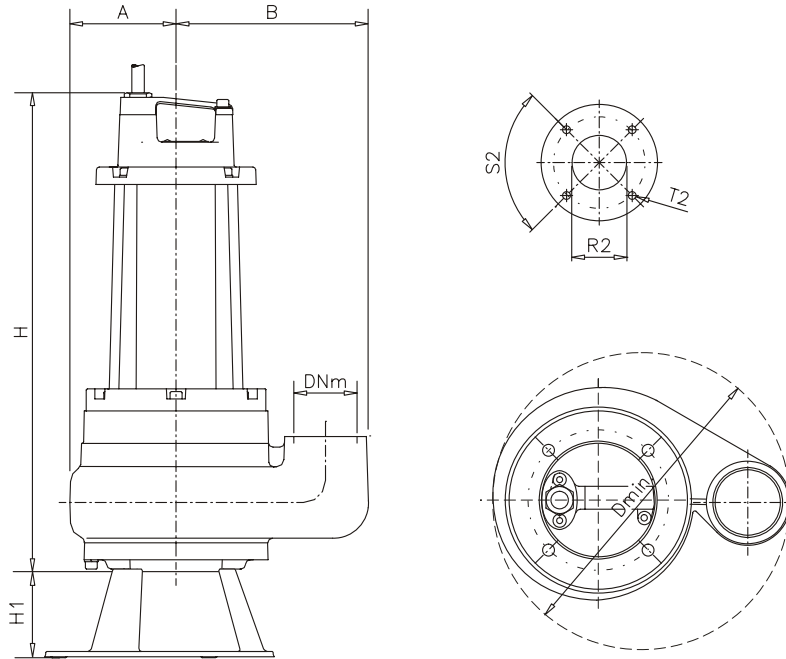

Outlet: Vertical GAS 2 1/2" thread

	A (mm)	B (mm)	Dmin (mm)	DNm (inch)	H (mm)	H1 (mm)	R2 (mm)	S2 (°)	T2			
MAN 300/2/G65V A1DT	109	203	310	GAS 2 1/2	564	124	76	90	M12			

Pump with coupling foot base dimensional drawing

Mass: 52 Kg

