

ELECTRO-MECHANICAL UNIT	Rated delivered power:	3.0 kW	Motor poles/revolutions:	2900 1/min – 2 Poles
	Rated absorbed power:	4.0 kW	Motor phases:	T - three phase
	Rated absorbed current:	6.7 A	Service:	S1 submersed or with cooling system -
	Starting current:	29.7 A	Motor protection:	IP 68
	Starting torque:	22,74 Nm	Insulation class (ICL):	H
	Rated Cos Ø:	0,86	Max. Starts per hour:	20
	Rated motor performance:	75%	Standard cable type:	H07RN-F 4G1,5 + 3x1 (10 m)
	Detailed description of series:	Submersible pump made of EN-GJL-250 cast iron, suitable for submersible operation, with 2 mechanical seals installed in an inspectable oil chamber. Dry motor.		
	Standard mechanical seals	2 Silicon Carbide mechanical seals in oil chamber		
	Lifting:	With handle on motor cover		
Ball bearings:	Upper and lower permanently lubricated ball bearings			
Winding type:	Induction motor with dry winding and manual thermal protection			
Impregnation type:	Doubly impregnated humidity-resistant winding			
Direction of rotation:	Clockwise seen from top of electric pump			
Data provided above refers to hydraulic tests carried out at: 400 Volt 50 Hz				

MATERIALS	Mechanical unit:	EN-GJL-250 cast-iron	Hyd. Unit, impeller:	EN-GJL-250 cast-iron
	Shaft:	AISI 420	Bolts and Screws:	INOX A2-70
	Seals (O-Ring):	NBR rubber	Grinder cutter:	-
	**Cooling jacket:	AISI 304 stainless steel	Painting:	Ecological epoxy vinyl
** Cooling jacket supplied upon request in series specified				

LIMITS ON USE REFERENCE STANDARDS	Max. operating temp.:	40° C	Max. sub. depth:	30 m
	Liquid PH:	6 ÷ 14	Liquid density:	1 Kg/dm3
	Viscosity of liquid:	1 mm2/s	Max. acoustic press.:	< 70 dB(A)
	Reference standards:			
<ul style="list-style-type: none"> ▪ MACHINE DIRECTIVE 89/392/EEC and subsequent amendments (directives: D1/368/EEC, 93/68/EEC); ▪ LOW VOLTAGE DIRECTIVE 73/ 23/ EEC; ▪ ELECTROMAGNETIC COMPATIBILITY DIRECTIVE 89/336/EEC; ▪ EN292-1; EN 292; UNI EN 414 CEI EN 60529; CEI EN 60034-1; CEI EN 60034-2; CEI EN 60335-1; CEI EN 60335-2-41; UNI EN 9906; CEI EN 60204; UNI EN 1561; UNI EN 1563; UNI EN 614; ▪ Procedures required by the Zenit S.r.l. Quality System. UNI EN 9001 certificate (ISO 9001), DNV certificate No. CERT-00660-95-AQ-BOLSINCERT. 				

VARIANTS AVAILABLE	Electrical accessories	
	T - TS	Thermostat - Thermostat and probe
	Set of mechanical seals	
	2SIC	2 Silicon Carbide mechanical seals in oil chamber
Cooling system / mechanical seal flushing versions*		
N - CC	No cooling system available - Cooling system using treated liquid	

Pump dimensional drawing

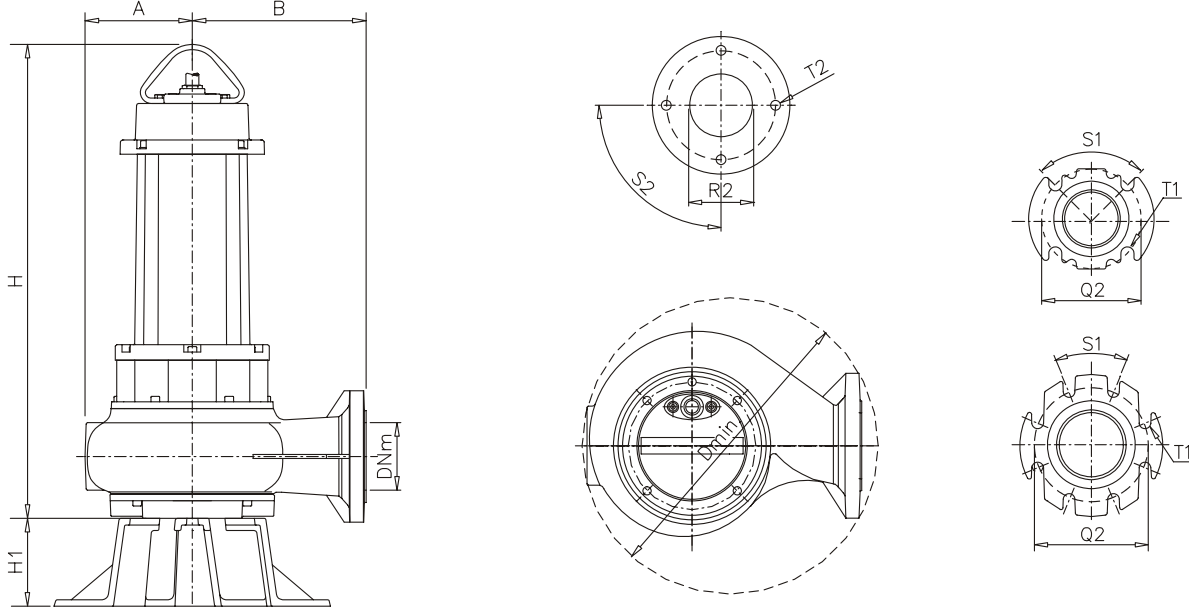

Outlet: Horizontal flange DN 80 PN 10

	A (mm)	B (mm)	Dmin (mm)	DNm (mm)	H (mm)	H1 (mm)	Q2 (mm)	R2 (mm)	S1 (°)	S2 (°)	T1 (mm)	T2
MAN 400/2/80 A1FT	135	210	375	80	687	145	160	76	90	90	16	M12

Pump with coupling foot base dimensional drawing

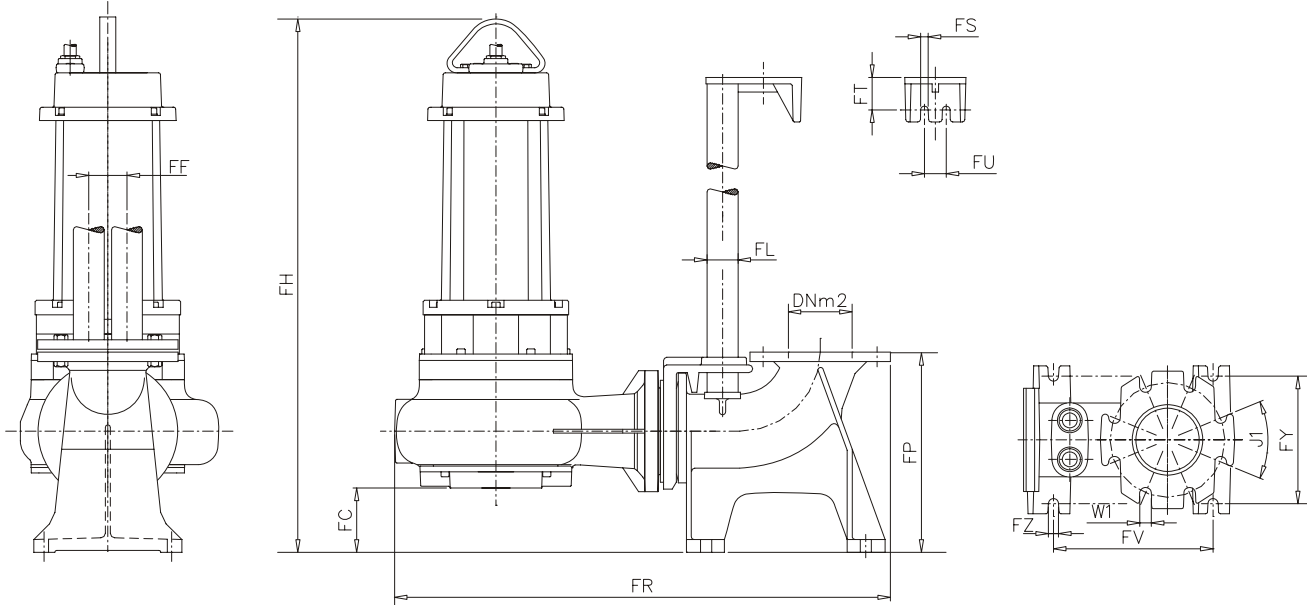

	DNm2 (mm)	FC (mm)	FF (mm)	FH (mm)	FL (inch)	FR (mm)	FS (mm)	FT (mm)
MAN 400/2/80 A1FT	80	110	61	799	1 ½	686	12	51
	FU (mm)	FV (mm)	FY (mm)	FZ (mm)	J1 (°)	W1 (mm)		
	34	250	200	16	90	18		

Mass: 74 Kg

